

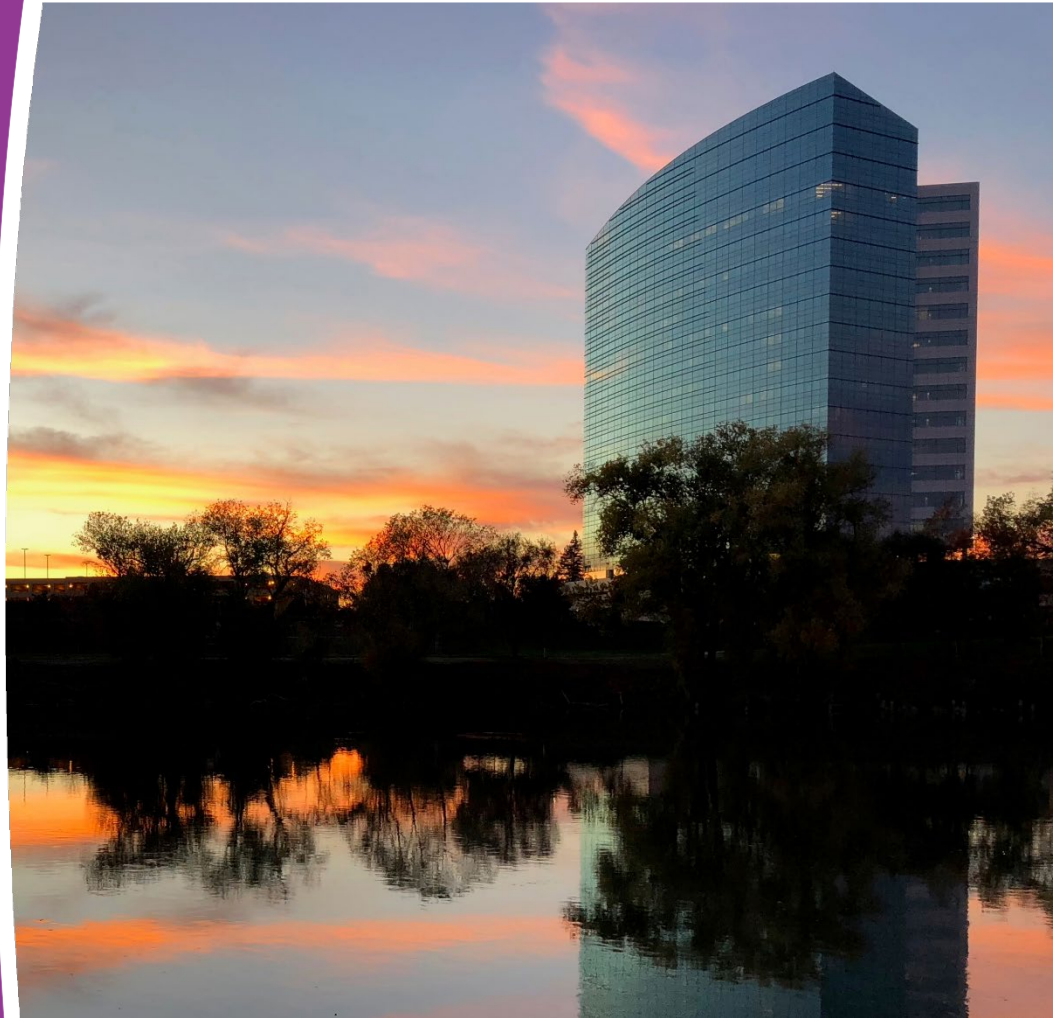

# Enterprise Technology Projects

FISCAL YEAR  
2023-24



## FOURTH QUARTER REPORT

Quarter Ending June 30, 2024

## ENTERPRISE TECHNOLOGY PROJECTS

FISCAL YEAR 2023-24  
FOURTH QUARTER REPORT

At the end of the fourth quarter for fiscal year 2023-24, CalSTRS had nine reportable enterprise projects: seven major technology projects over \$1 million and two projects under \$1 million.

The Project Support Office monitors and reports monthly on the technology appropriations budget and enterprise projects' status to the Enterprise Program Investment Council and quarterly to the Teachers' Retirement Board.

## ENTERPRISE PROGRAM INVESTMENT COUNCIL MEMBERS

**Cassandra Lichnock**

Chief Executive Officer

**Julie Underwood**

Chief Financial Officer

**Teresa Schilling**

Chief Public Affairs Officer

**Bill Perez**

Chief Benefits Officer

**Lisa Blatnick**

Chief Operating Officer

**Melissa Norcia**

Chief Administrative Officer

**Ashish Jain**















Chief Technology Officer

**Scott Chan**

Deputy Chief Investment Officer

## MAJOR ENTERPRISE TECHNOLOGY PROJECTS

The following table summarizes current major enterprise technology projects during the fourth quarter.

Project Name	Project Duration	Schedule (Status)	Project Budget	Budget Expended	Budget (Status)
BusinessDirect Retrofit <sup>1</sup>	Apr 2017 – Jun 2027	 <sup>2</sup>	\$9,769,238	\$8,486,731	
Contact Center Modernization	Jun 2023 – Mar 2025		\$1,375,000	\$542,570	
Data Quality	Nov 2011 – Jun 2027	 <sup>3</sup>	\$37,536,915 <sup>4</sup>	\$33,241,918	
Datacenter Hosting and Migration Services	Nov 2020 – Jun 2026		\$31,595,000	\$19,031,835	
Pension Solution	Jul 2014 <sup>5</sup> – Jun 2027		\$422,006,496 <sup>6</sup>	\$376,425,750	
SAP Ariba <sup>7</sup>	Apr 2024 – Dec 2025		\$7,280,000	\$10,901	
Transformation Readiness	Jul 2016 – Jun 2027	 <sup>8</sup>	\$25,374,441 <sup>9</sup>	\$21,359,269	

Schedule & Budget Indicators:  On Track  Warning  Critical  Complete  On Hold  Cancelled  Not Started

<sup>1</sup> BusinessDirect Retrofit: All remaining tasks are being integrated into the Pension Solution Project. Therefore, the status of this project will be reported as part of the Pension Solution Project and will not be reported separately in future reports.

<sup>2</sup> BusinessDirect Retrofit: A change request was approved by the Enterprise Program Investment Council in May 2024 to extend the schedule through June 2027 to coincide with the Pension Solution Project end date.

<sup>3, 4</sup> Data Quality: A change request was approved by the Enterprise Program Investment Council in May 2024 to increase the budget to cover project costs through June 30, 2025, and extend the schedule through June 2027 to coincide with the Pension Solution Project end date.

<sup>5</sup> Pension Solution: The project's start date represents the effective date of the first comprehensive project budget approved by the Teachers' Retirement Board and enacted through a Budget Change Proposal during the annual budget process. Pre-implementation project activities (e.g., discovery, requirements, and procurement) began in 2010.

<sup>6</sup> Pension Solution: The project is seeking \$205.8M in additional funding via the Budget Change Proposal process, with funding being available in July 2024.

<sup>7</sup> SAP Ariba: A project request was approved by the Enterprise Program Investment Council in April 2024 to procure and implement SAP Ariba to replace CalSTRS current procurement solution that will reach end-of-life and end-of-support in December 2027.

<sup>8, 9</sup> Transformation Readiness: A change request was approved by the Enterprise Program Investment Council in May 2024 to increase the budget to cover project costs through June 30, 2025, and extend the schedule through June 2027 to coincide with the Pension Solution Project end date.

# MAJOR ENTERPRISE TECHNOLOGY PROJECTS

## BUSINESSDIRECT RETROFIT

The BusinessDirect Retrofit (BDR) Project will support CalSTRS in the implementation of a new pension administration system, BenefitConnect (BC). This will be accomplished by modifying BusinessDirect (BD) to migrate specific pension functionality out of BD and into BC, building new interfaces between BD and BC, modifying some existing interfaces between BD and BC and external entities, and extracting/mapping historical data from BD to BC to support functionality migration.

NOTE: The remaining work for the BDR Project stems from implementation activities for the BenefitConnect solution for the Pension Solution Project. Therefore, it is no longer an effective use of resources to maintain a separate project and budget. As a result, all remaining tasks and costs are being integrated into the Pension Solution Project schedule and budget. The integration is not expected to increase the total Pension Solution Project budget. The status of this project will be reported as part of the Pension Solution Project and will not be reported separately in future reports. In addition, any remaining funds from a source outside of the Pension Solution Project will be returned to that funding source.

### PROJECT BUDGET

\$9.8 Million

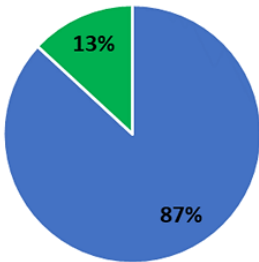

■ % Expended ■ % Remaining

### ACCOMPLISHMENTS – PERIOD ENDING JUNE 30, 2024

- Continued parallel testing with Pension Solution Project.
- Continued monitoring of Pension Solution Project activities and worked with system support vendor for resolution of outstanding defects, as needed.
- Continued to identify new and modified Pension Solution Project requirements that impact the BDR Project.

### PLANNED MAJOR ACTIVITIES & MILESTONES BY SEPTEMBER 30, 2024

- Finalize the schedule with vendor.
- Incorporate the final schedule with Pension Solution Project schedule.

### PROJECT SCHEDULE PERCENT COMPLETE



### FISCAL YEAR 2023–24 MAJOR MILESTONES

The BDR Project schedule is dependent on the Pension Solution Project schedule. Due to schedule replanning efforts for the Pension Solution Project, there are no major milestones to report for the BDR Project in Fiscal Year 2023-24. Future major milestones will be reported with the Pension Solution Project.



## MAJOR ENTERPRISE TECHNOLOGY PROJECTS

### CONTACT CENTER MODERNIZATION

The Contact Center Modernization Project will replace the current Contact Center platform, Genesys, with the NICE CXone platform. Objectives include:

- Maintain existing functionality that CalSTRS currently uses in the Genesys platform.
- Maintain current member service levels (e.g., member satisfaction, member wait time, etc.).
- Decommission current Genesys system by February 2024 when contract expires.

#### PROJECT BUDGET

\$1.375 Million

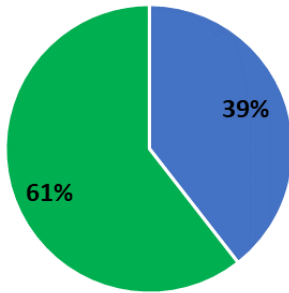

■ % Expended ■ % Remaining

#### ACCOMPLISHMENTS – PERIOD ENDING JUNE 30, 2024

- Completed Phase II planning activities.
- Completed Phase II scoping discussions both internally and with vendors.
- Finalized Statement of Work and vetted through CalSTRS Procurement.
- Executed contract with AT&T for Phase II.

#### PLANNED MAJOR ACTIVITIES & MILESTONES BY SEPTEMBER 30, 2024

- Complete requirements gathering for Phase II workstreams.
- Implement IEX's Workforce Management single sign-on.
- Implement Speech-to-Text Analytics and Feedback Management (Point-of-Service surveys)
- Implement integration between the Feedback Management and Performance Management products.
- Complete development for Automated Speech Recognition.

#### PROJECT SCHEDULE PERCENT COMPLETE



#### FISCAL YEAR 2023–24 MAJOR MILESTONES

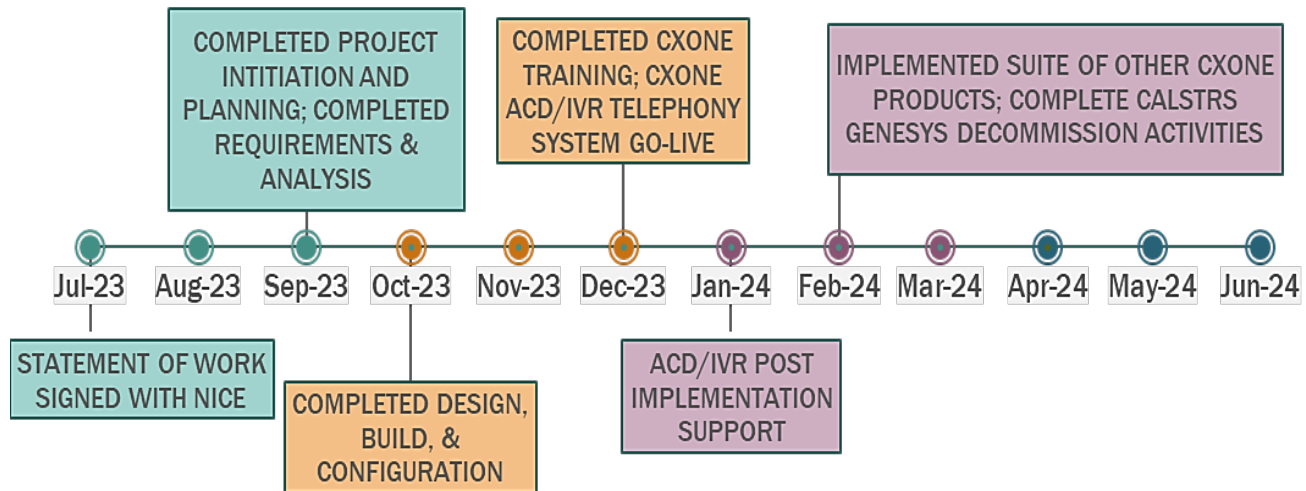

NOTE: ACD = AUTOMATIC CALL DISTRIBUTION; IVR = INTERACTIVE VOICE RESPONSE

## MAJOR ENTERPRISE TECHNOLOGY PROJECTS

### DATA QUALITY

The Data Quality Project will prepare the legacy pension administration data for conversion to BenefitConnect (BC), the new pension administration system. The project is in the second phase of data cleansing and includes data clean-up, rerun of data fixes, resolution of conversion fallout and preparation for data conversion.

NOTE: A change request was approved by the Enterprise Program Investment Council in May 2024 to increase the budget to cover project costs through June 30, 2025, and extend the schedule through June 2027 to coincide with the Pension Solution Project end date.

#### PROJECT BUDGET

\$37.5 Million

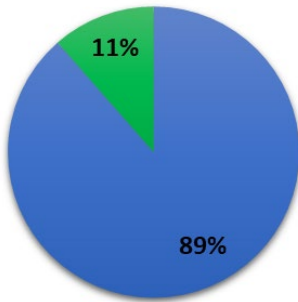

■ % Expended ■ % Remaining

#### ACCOMPLISHMENTS – PERIOD ENDING JUNE 30, 2024

- Complete Annual Member Lifecycle Fix A. This fix backdates membership dates in the legacy pension administration system to align with the earliest employer reporting information received for a member's account.
- Complete Annual Member Lifecycle Fix B. This fix reverses and re-reports employer reporting information in the legacy pension administration system to ensure there is no creditable service received after a benefit effective date to align with BC business rules and functional requirements.

#### PLANNED MAJOR ACTIVITIES & MILESTONES BY SEPTEMBER 30, 2024

- Complete Annual Member Lifecycle Fix D. Similarly to Fix B, this fix reverses and re-reports employer reporting information in the legacy pension administration system to ensure there is no creditable service received after a benefit effective date to align with BC business rules and functional requirements.

#### PROJECT SCHEDULE PERCENT COMPLETE

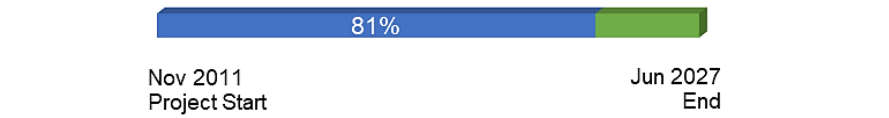

#### FISCAL YEAR 2023–24 MAJOR MILESTONES<sup>10</sup>

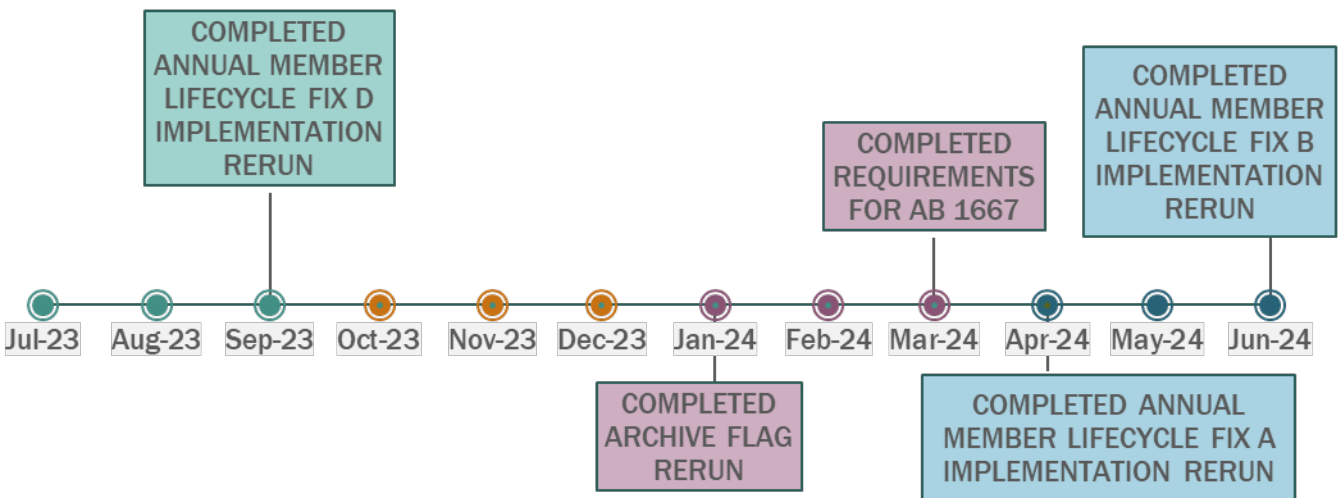

<sup>10</sup> As approved by Pension Solution Steering Committee.



# MAJOR ENTERPRISE TECHNOLOGY PROJECTS

## DATACENTER HOSTING AND MIGRATION SERVICES

The Datacenter Hosting and Migration Services (DHMS) Project will enable CalSTRS to mitigate the business continuity risks, support CalSTRS enterprise strategic goals, and establish a flexible framework for operational efficiency and cost optimization through the migration of on-premises critical systems/equipment onto a multi-modal data center solution.

### PROJECT BUDGET

\$31.6 Million

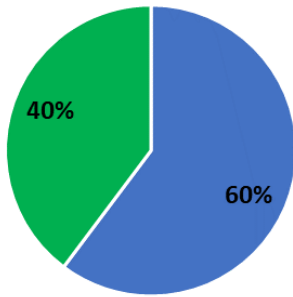

■ % Expended ■ % Remaining

### ACCOMPLISHMENTS – PERIOD ENDING JUNE 30, 2024

- Completed migration of CalSTRS critical applications from DHMS Amazon Web Services (AWS) to CalSTRS AWS Platform.

### PLANNED MAJOR ACTIVITIES & MILESTONES BY SEPTEMBER 30, 2024

- Complete Amendment 4 to extend the vendor’s service agreement for 4 months (October 2, 2024 – January 31, 2025) to continue to manage the maintenance and operations activities for the remaining DHMS AWS environment supporting Horizon Virtual Desktop Infrastructure (VDI).
- Complete Proof of Concept of a Desktop-as-a-Service solution to replace Horizon VDI before the end of 2024 in CalSTRS AWS Platform.

### PROJECT SCHEDULE PERCENT COMPLETE



### FISCAL YEAR 2023–24 MAJOR MILESTONES

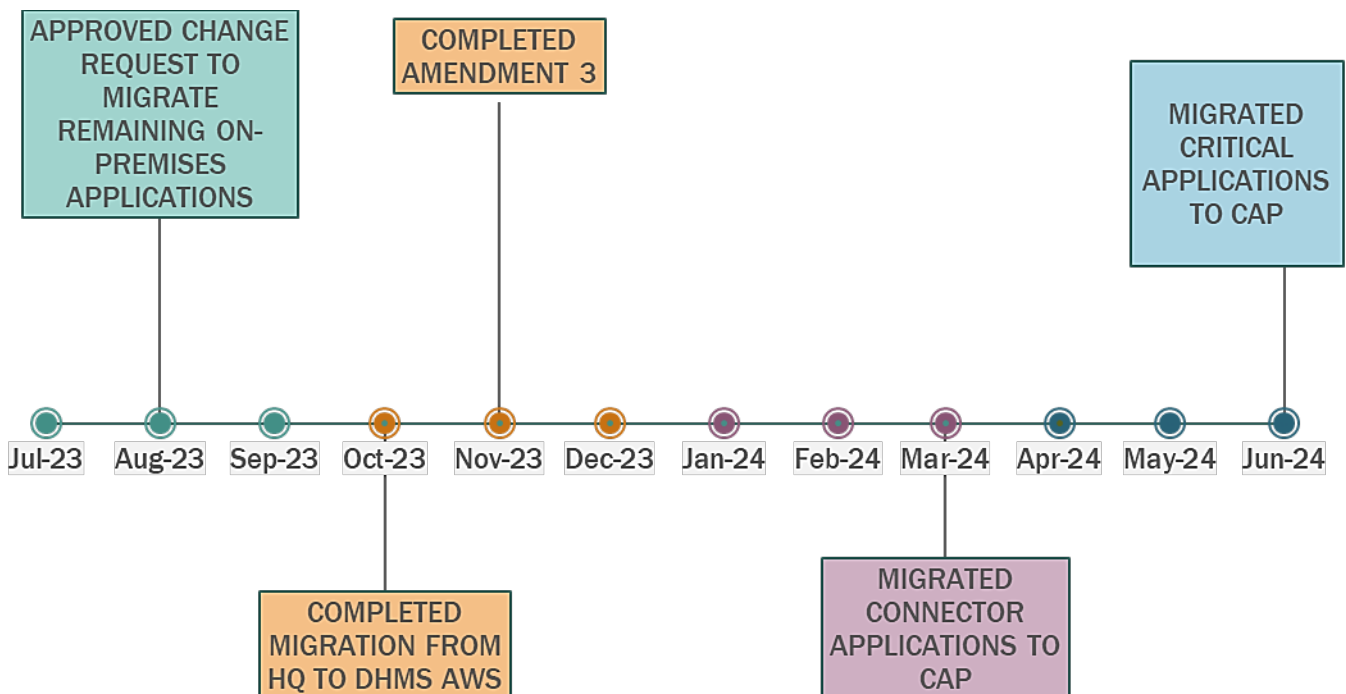

NOTE: VDI = Virtual Desktop Infrastructure; AWS = Amazon Web Service; CAP = CalSTRS AWS Platform

# MAJOR ENTERPRISE TECHNOLOGY PROJECTS

## PENSION SOLUTION

The Pension Solution Project will replace CalSTRS legacy pension administration system with a new solution, BenefitConnect, to increase the organization’s ability to respond to business and customer needs, enhance services to members, beneficiaries, staff, and employers, gain long-term operational efficiencies, and improve internal controls.

### PROJECT BUDGET

\$422 Million<sup>11</sup>

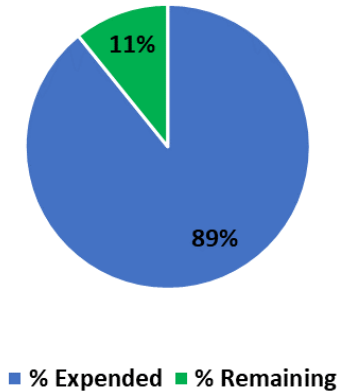

### ACCOMPLISHMENTS – PERIOD ENDING JUNE 30, 2024

- Commenced System Integration Testing Stream 4.
- Completed migration from three Quest Data Centers to AWS.
- Completed SIT Stream 3 Checkpoint.
- Completed SIT Testing Set 1.
- Completed the User Acceptance Testing Detailed Test Plan.
- Commenced UAT test case development activities.
- Completed Functional Rollouts 2 and 3 Combined Rollout Business Process Reengineering Document.
- Completed design and plans for Artificial Intelligence use case Proof of Concept efforts.
- Completed infrastructure buildout for Pension Solution AI solution.

### PLANNED MAJOR ACTIVITIES & MILESTONES BY SEPTEMBER 30, 2024

- Refine and approve the Requirements Traceability Matrix.
- Complete development of mandated design requests.
- Complete SIT Sets 2 and 3.
- Complete SIT Stream 4 Checkpoint.
- Commence SIT Stream 5.
- Complete testing of batches and interfaces for go-live.
- Complete exploratory, automated regression and CalSTRS-focused test activities.
- Commence end-to-end, usability, performance testing.
- Complete migration of On-Prem Pension environments to Amazon Web Services.
- Complete initial AI POC.
- Complete delivery of UAT execution training.
- Conduct Test Readiness Review meeting to confirm UAT commencement.
- Complete the Implementation Plan deliverable.
- Complete/approve Requirements Traceability Matrix deliverable.

### PROJECT SCHEDULE PERCENT COMPLETE

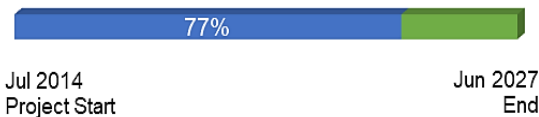

### FISCAL YEAR 2023–24 MAJOR MILESTONES

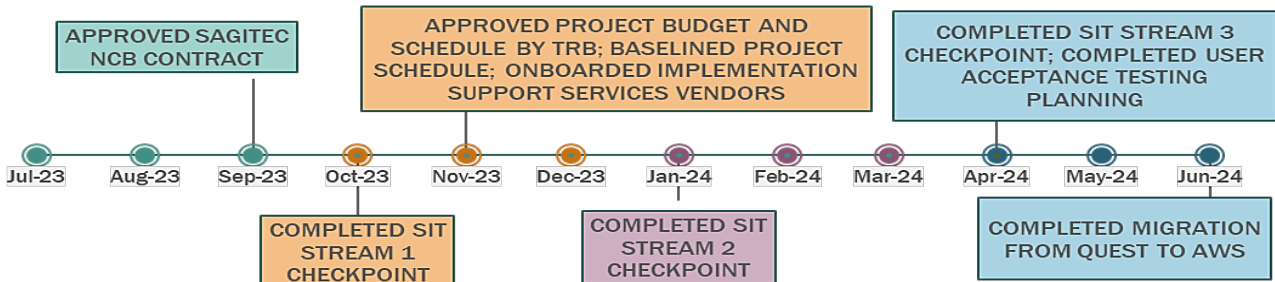

NOTE: NCB = Non-Competitive Bid; AWS = Amazon Web Service; SIT = System Integration Testing

<sup>11</sup> Project is seeking \$205.8M in additional funding via the Budget Change Proposal process, with funding being available in July 2024.



## MAJOR ENTERPRISE TECHNOLOGY PROJECTS

### SAP ARIBA

The SAP Ariba Project will procure and implement the next-generation cloud-based SAP procurement solution, SAP Ariba, to replace CalSTRS current source-to-pay solutions, SAP Supplier Relationship Management (SRM) and Supplier Self Service (SUS) Portal (Invoicing) before they reach end-of-life and end-of-support in December 2027. SAP Ariba will enhance CalSTRS supply chain and procurement processes and source-to-contract and procure-to-pay workflows to streamline the purchasing lifecycle, improve supplier collaboration, and optimize procurement operations.

#### PROJECT BUDGET

\$7.3 Million

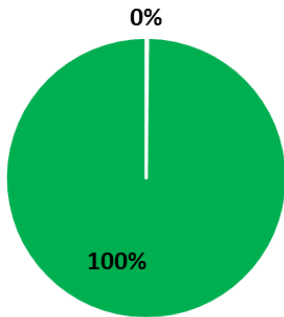

■ % Expended ■ % Remaining

#### ACCOMPLISHMENTS – PERIOD ENDING JUNE 30, 2024

- Teacher’s Retirement Board approved a change request to the SAP maintenance and operations contract with Deloitte to perform implementation efforts for the SAP Ariba Project.
- Completed contract negotiations with Deloitte for the Scope of Work and Requirements.
- Completed hiring of staff to participate as subject matter experts during the implementation.

#### PLANNED MAJOR ACTIVITIES & MILESTONES BY SEPTEMBER 30, 2024

- Onboard Deloitte implementation project team.
- Conduct project kickoff.
- Commence design workshops.
- Complete procurement and setup of SAP Ariba staging and production environments to be used during implementation.

#### PROJECT SCHEDULE PERCENT COMPLETE



#### FISCAL YEAR 2023–24 MAJOR MILESTONES

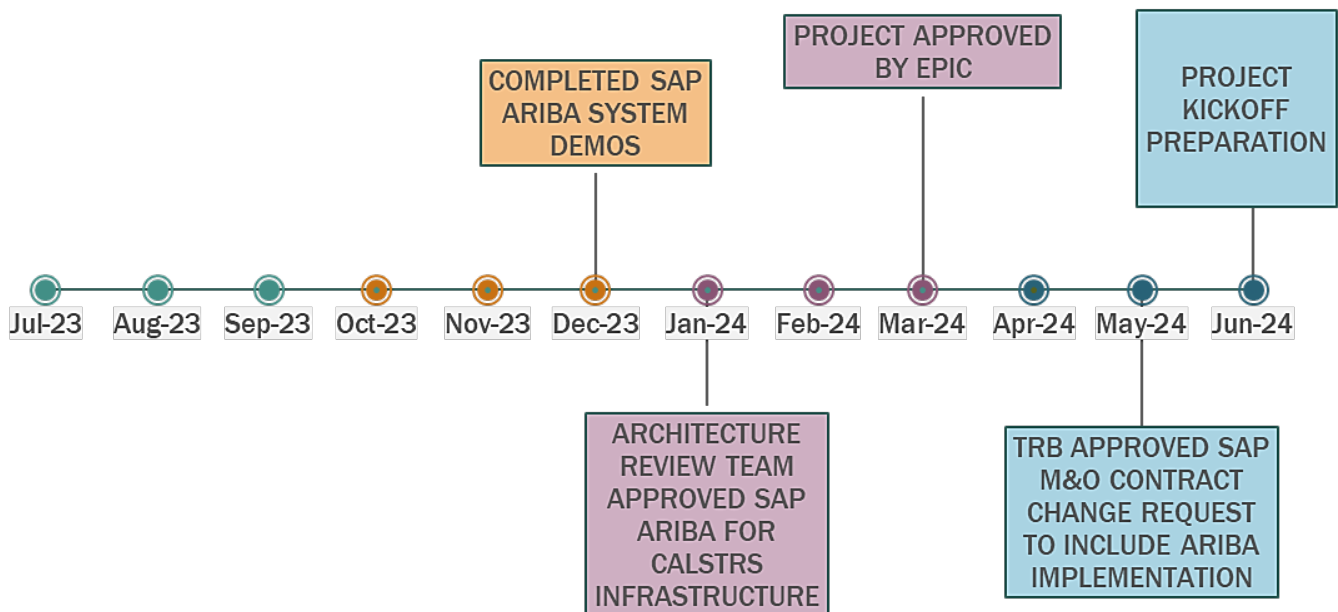

# MAJOR ENTERPRISE TECHNOLOGY PROJECTS

## TRANSFORMATION READINESS

The Transformation Readiness Project supports business areas and prepares staff for impacts, changes, and benefits from large enterprise modernization efforts. Transformation Readiness will work closely with Pension Solution Project leadership to ensure that change management and learning activities are completed respective to the project schedule.

NOTE: A change request was approved by the Enterprise Program Investment Council in May 2024 to increase the budget to cover project costs through June 30, 2025, and extend the schedule through June 2027 to coincide with the Pension Solution Project end date.

### PROJECT BUDGET

\$25.4 Million

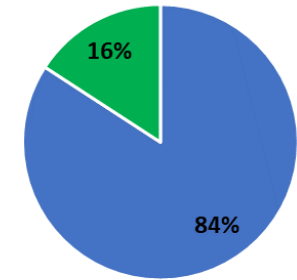

■ % Expended ■ % Remaining

### ACCOMPLISHMENTS – PERIOD ENDING JUNE 30, 2024

- Hired and onboarded two change management Associate Governmental Program Analysts.
- Completed the Pension Solution Project training design milestone by conducting two kick-off meetings supporting training stakeholders and completed 48 Pension Solution training course outlines.
- Conducted the Training Development kick-off meeting with training stakeholders and began training material development.
- Finalized and published Del 8.2 Train-the-Trainer Model.
- Completed the Stakeholder Management Plan, which defines the strategy to ensure all impacted stakeholders are kept informed to the degree necessary and included in all activities that require their participation.
- Conducted change management assessments of internal stakeholders.
- Provided customized change management plans and communications for several internal stakeholders.
- Refreshed Change Champion roster

### PLANNED MAJOR ACTIVITIES & MILESTONES BY SEPTEMBER 30, 2024

- Conduct internal Pension Solution survey to allow Change Management and senior leadership to understand possible gaps and blockers, improve communications, and solidify support going forward.
- Continue customizing change management plans and communications for several internal stakeholders.
- Conduct summer Change Champion meeting.
- Continue change management assessments on internal stakeholders.
- Complete training material development for 18 courses supporting the Pension Solution Project.
- Complete the stakeholder kick-off for first phase of training development.

### PROJECT SCHEDULE PERCENT COMPLETE





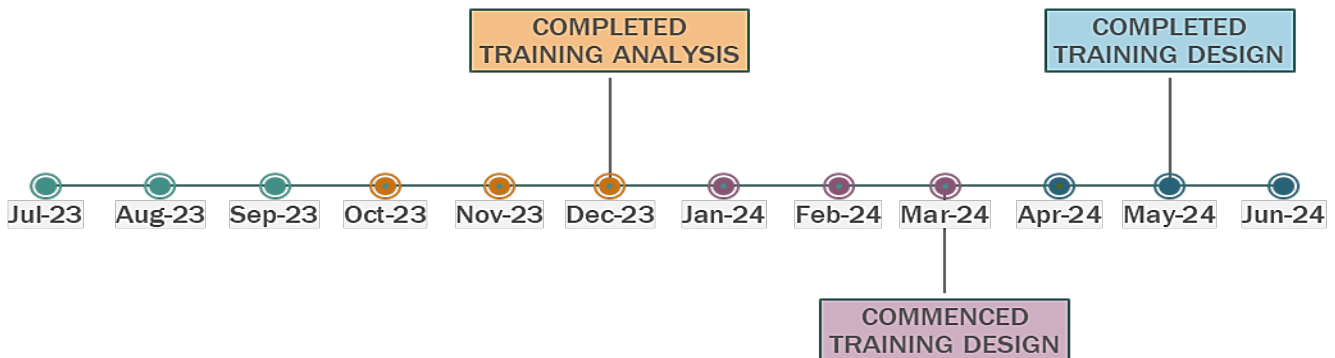

### FISCAL YEAR 2023–24 MAJOR MILESTONES



OTHER ENTERPRISE PROJECTS UNDER \$1 MILLION

The following table summarizes other reportable enterprise projects under \$1 million during the fourth quarter.

Project and Description	Project Duration	Schedule (Status)	Project Budget	Budget Expended	Budget (Status)
<p><b>Customer Relationship Management Solution Readiness Assessment</b></p> <p>Conduct an assessment to determine the viability, benefits, and timing of acquiring a customer relationship management tool to support CalSTRS business strategy for enhancing the customer experience, improving engagement, and increasing efficiency.</p>	Feb 2023 – Apr 2024		\$476,824	\$476,824	
<p><b>Print to Mail Software</b></p> <p>Install and integrate Pitney Bowes print-to-mail software, Planet Press, between the new pension administration system, BenefitConnect, and CalSTRS centralized printer. Provides the ability to process outgoing member correspondence in zip code order and varying page-counts, to align with how it is generated by BenefitConnect. Provides a modern print-to-mail software solution with more automated workflow and built-in security oversight protections and risk-mitigation measures.</p>	Dec 2020 – Jun 2027		\$559,283	\$140,495	

Schedule & Budget Indicators:  On Track  Warning  Critical  Complete  On Hold  Cancelled  Not Started

<sup>12</sup> Print to Mail: A change request was approved by the Enterprise Program Investment Council in May 2024 to extend the schedule through June 2027 to coincide with the Pension Solution Project end date.