

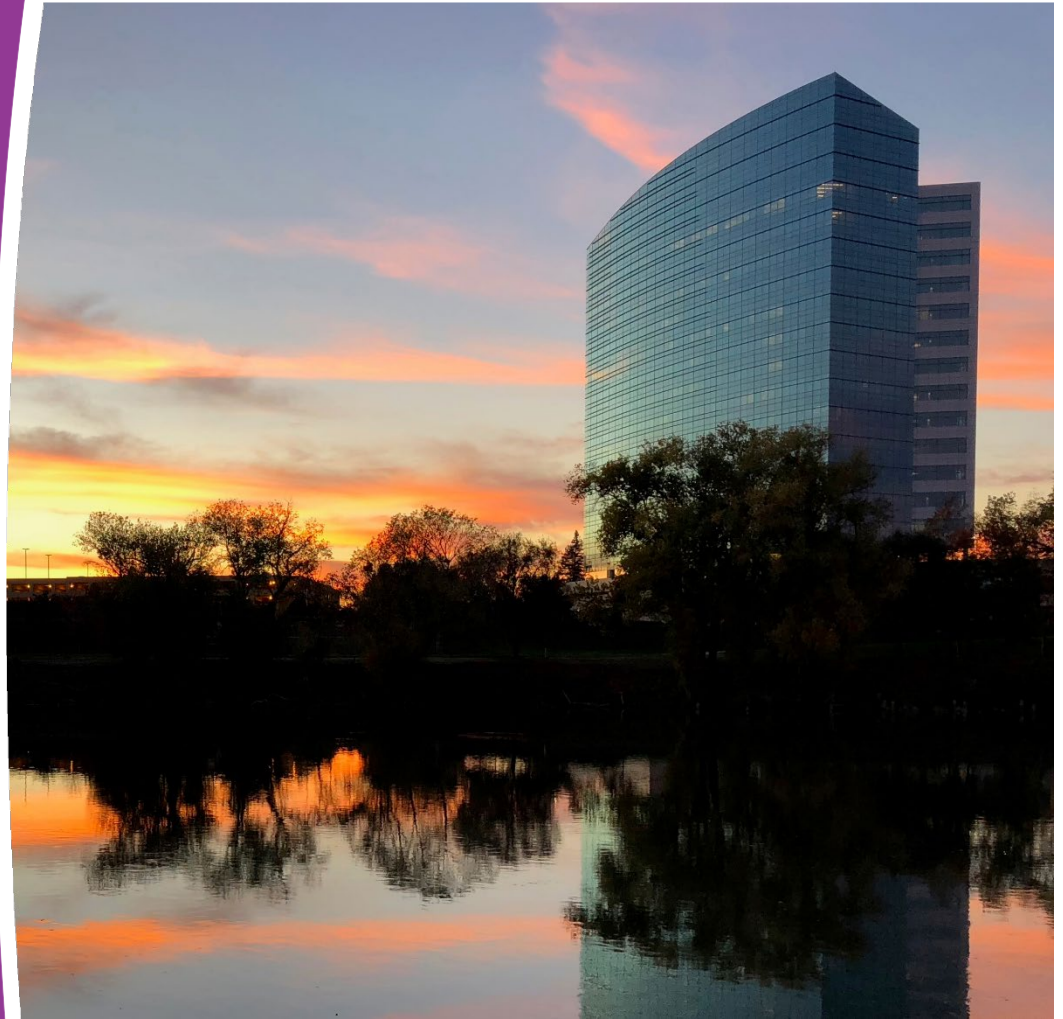

# Enterprise Technology Projects

FISCAL YEAR

2021-22



**FIRST QUARTER REPORT**

Quarter Ending September 30, 2021

## ENTERPRISE TECHNOLOGY PROJECTS

FISCAL YEAR 2021-22  
FIRST QUARTER REPORT

At the end of the first quarter for fiscal year 2021-22, CalSTRS had nine enterprise projects: six major technology projects over \$1 million and three additional projects under \$1 million.

The Project Support Office monitors and reports monthly on the technology appropriations budget and enterprise projects' status to the Enterprise Program Investment Council and quarterly to the Teachers' Retirement Board.

## ENTERPRISE PROGRAM INVESTMENT COUNCIL MEMBERS

**Cassandra Lichnock**  
Chief Executive Officer

**Lisa Blatnick**  
Chief Operating Officer

**Julie Underwood**  
Chief Financial Officer

**Melissa Norcia**  
Chief Administrative Officer

**Teresa Schilling**  
Chief Public Affairs Officer













**Ashish Jain**  
Chief Technology Officer

**Bill Perez**  
Chief Benefits Officer

**Scott Chan**  
Deputy Chief Investment Officer

## MAJOR ENTERPRISE TECHNOLOGY PROJECTS

The following table summarizes current major enterprise technology projects during the first quarter.

Project Name	Project Duration	Schedule (Status)	Project Budget <sup>1</sup>	Budget Expended <sup>2</sup>	Budget (Status)
BusinessDirect Retrofit	Jul 2018 – Jan 2022	 <sup>3</sup>	\$9,769,238 <sup>4</sup>	\$5,566,303	
Data Quality	Nov 2011 – Jun 2022		\$30,910,879	\$25,777,002	
Datacenter Hosting and Migration Services	Nov 2020 – Oct 2023		\$19,900,000	\$1,638,941	
HR Link	Dec 2018 – Nov 2021		\$1,572,667	\$659,621	
Pension Solution	Jul 2014 – Feb 2023	 <sup>5</sup>	\$304,833,040	\$212,826,100	
Transformation Readiness	Jul 2016 – Jun 2022		\$18,356,368	\$13,964,522	

*Schedule & Budget Indicators*  *On Track*  *Warning*  *Critical*  *Complete*  *Cancelled*  *Not Started*

<sup>1</sup> Project Budget – Amount represents the sum of the projects' prior years' actual expended, remaining encumbrances, and current and future years budgeted amounts.

<sup>2</sup> Budget Expended – Amount represents the total expended.

<sup>3</sup> BusinessDirect Retrofit – The schedule is dependent on the implementation schedule for the Pension Solution Project.

<sup>4</sup> BusinessDirect Retrofit – In addition to the amount reported above, the Pension Solution Project is providing \$5.4 Million funding for system enhancements to pension administration-related functionality.

<sup>5</sup> Pension Solution – The yellow indicator is due to the vendor experiencing significant delays with Contractor Acceptance Testing - Part B for Functional Rollout 2. CalSTRS is also experiencing a lower-than-expected pass rate in User Acceptance Testing. Additionally, the vendor is making slower progress in fixing the defects than anticipated. The delayed completion is impacting the project schedule and all downstream project activities including User Acceptance Testing and the Go-Live dates for both FR2 and FR3.

## MAJOR ENTERPRISE TECHNOLOGY PROJECTS

### BUSINESSDIRECT RETROFIT

The BusinessDirect Retrofit project goals and objectives are to support CalSTRS in the implementation of a new pension administration system, BenefitConnect. This will be accomplished by modifying BD to migrate specific pension functionality out of BD and into BC, building new interfaces between BD and BC, modifying some existing interfaces between BD and BC and external entities, and extracting/mapping historical data from BD to BC to support functionality migration.

NOTE: The schedule for this project is dependent on the Pension Solution Project schedule, for which, as noted in this report, a complete schedule and budget (including milestones, cost, and staffing) analysis is being conducted. For this reason, it is unknown at this time what major activities and milestones will be completed during this quarter.

#### PROJECT BUDGET

\$9.8 Million

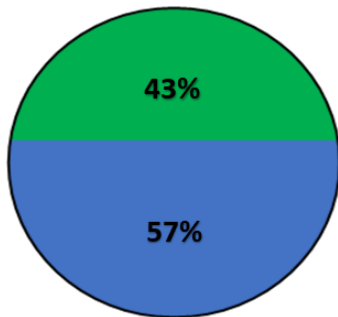

● % Expended ● % Remaining

#### ACCOMPLISHMENTS – PERIOD ENDING SEPTEMBER 30, 2021

- Passed 136 out of 301 test cases for User Acceptance Testing.
- Completed training materials and associated traceability matrix (deliverable) for the Financial Services Branch.

#### PLANNED MAJOR ACTIVITIES & MILESTONES BY DECEMBER 31, 2021

- Complete Integration Testing Pension Solution Change Requests (Part 1).

#### PROJECT SCHEDULE STATUS TIMELINE

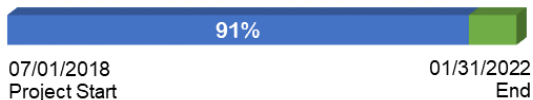

#### FISCAL YEAR 2021–22 MAJOR MILESTONES

Because the schedule for this project is dependent on the Pension Solution Project schedule, the expected milestone dates are unknown until the schedule for the Pension Solution Project has been reforecast.



## MAJOR ENTERPRISE TECHNOLOGY PROJECTS

### DATA QUALITY

The Data Quality project is in the second phase of data cleansing to include data clean-up and preparation for conversion to the new pension administration system.

NOTE: The schedule for this project is dependent on the Pension Solution Project schedule, for which, as noted in this report, a complete schedule and budget (including milestones, cost, and staffing) analysis is being conducted. For this reason, the Planned Major Activities from the prior report were not accomplished but will be added back to the report after the new schedule is finalized.

#### PROJECT BUDGET

\$30.9 Million

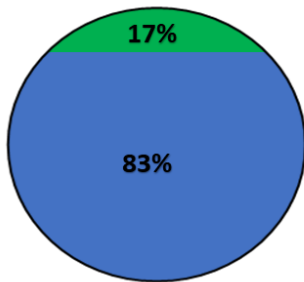

● % Expended ● % Remaining

#### ACCOMPLISHMENTS – PERIOD ENDING SEPTEMBER 30, 2021

- Reran one basic issue.
- Completed testing for Member Lifecycle Fix A rerun.

#### PLANNED MAJOR ACTIVITIES & MILESTONES BY DECEMBER 31, 2021

- Prepare data fixes to rerun.

#### PROJECT SCHEDULE STATUS TIMELINE

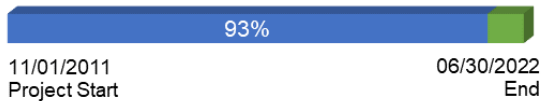

#### FISCAL YEAR 2021–22 MAJOR MILESTONES<sup>6</sup>

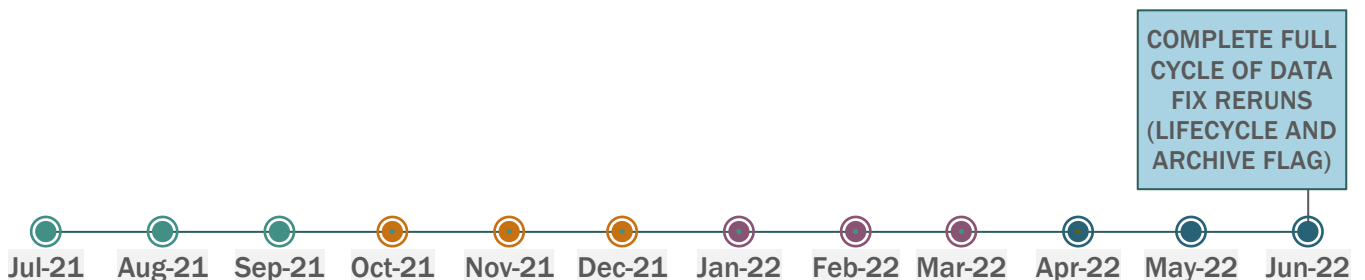

<sup>6</sup> As approved by Pension Solution Steering Committee.

## MAJOR ENTERPRISE TECHNOLOGY PROJECTS

### DATACENTER HOSTING AND MIGRATION SERVICES

The Datacenter Hosting and Migration Services project will enable CalSTRS to mitigate the business continuity risks, supports CalSTRS enterprise strategic goals, and establishes a flexible framework for operational efficiency and cost optimization through the migration of on-premise critical systems/equipment onto a multi-modal data center solution.

#### PROJECT BUDGET

\$19.9 Million

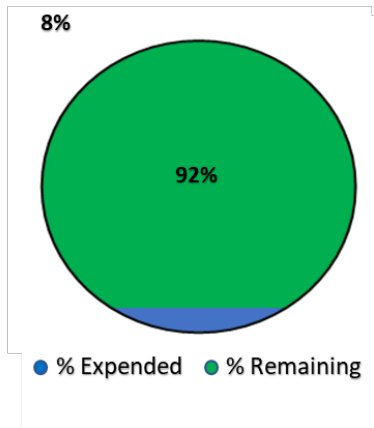

#### ACCOMPLISHMENTS – PERIOD ENDING SEPTEMBER 30, 2021

- Migrated the non-production environments for 403b Compare and Online Forms to AWS.

#### PLANNED MAJOR ACTIVITIES & MILESTONES BY DECEMBER 30, 2021

- Complete the re-baseline of the DHMS Project Schedule
- Complete the Proof of Viable Service by successfully migrating directory services and the production environments for 403B Compare and Online Forms into the AWS cloud.
- Complete the designs for remote access solutions.
- Start the migration of the Electronic Content Management System and related Connectors, BusinessDirect and related Connectors, Investment CPEs, and Contact Center solutions.

#### PROJECT SCHEDULE STATUS TIMELINE



#### FISCAL YEAR 2021–22 MAJOR MILESTONES

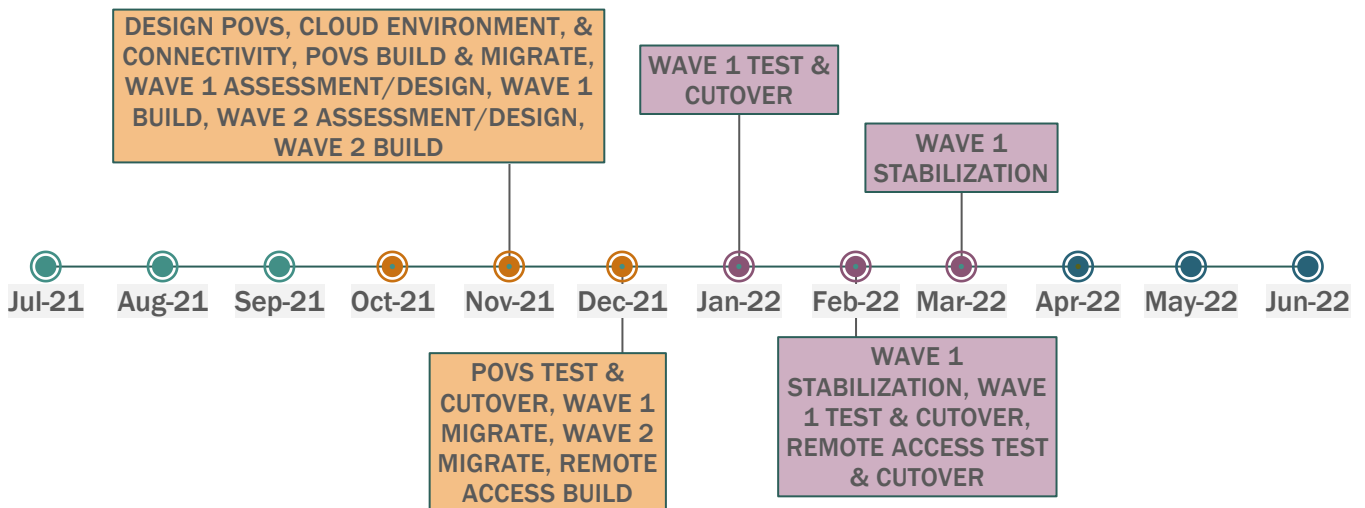

## MAJOR ENTERPRISE TECHNOLOGY PROJECTS

### HR LINK

The HR Link project will improve efficiencies by automating Human Resource processes, delivering real-time data and a self-service platform for all CalSTRS staff. The solution includes a core HR platform and tools for time management, learning and development, performance and goals, succession planning, onboarding, workforce planning and analytics. This is a multi-year project that will be implemented in phases. Employee Central and Learning and Development are the first modules and include a core HR platform, time and attendance management, and a learning management system.

NOTE: A Change Request is in process to extend the project through January 31, 2022 to accommodate changes to Phase 1 and Phase 2 planning. The content in the Timeline and Major Milestones graphs below reflects the Phase 1 milestone that is expected to be approved in October 2021.

### PROJECT BUDGET

\$1.5 Million

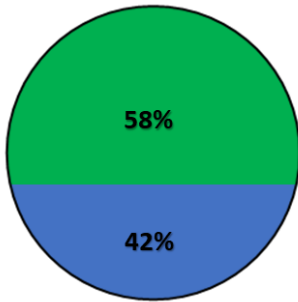

● % Expended ● % Remaining

### ACCOMPLISHMENTS – PERIOD ENDING SEPTEMBER 30, 2021

- Completed Learning Management System Testing.
- Integration development completed.

### PLANNED MAJOR ACTIVITIES & MILESTONES BY DECEMBER 31, 2021

- Complete training material development.
- Deliver HR Link training to organization.
- Complete Phase 1 HR Link testing.
- Phase 1 system go-live.

### PROJECT SCHEDULE STATUS TIMELINE

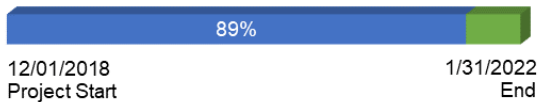

### FISCAL YEAR 2021–22 MAJOR MILESTONES

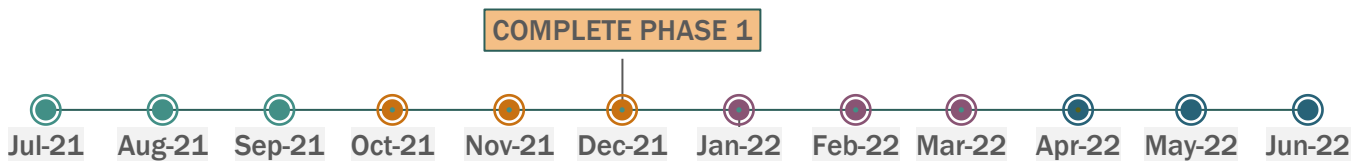

## MAJOR ENTERPRISE TECHNOLOGY PROJECTS

### PENSION SOLUTION

The Pension Solution Project will replace the CalSTRS legacy pension administration system to increase the organization's ability to respond to business and customer needs; enhance services to members, beneficiaries, staff and employers; gain long-term operational efficiencies; and improve internal controls.

NOTE: A complete analysis is being conducted for the schedule and budget (including milestones, cost, and staffing) for the project. A Change Request is expected to be submitted once the analysis is complete. Once the CR is approved, the graphs below will be updated.

#### PROJECT BUDGET

\$304.8 Million

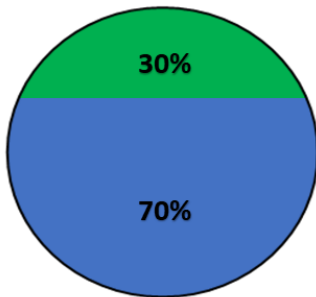

● % Expended ● % Remaining

#### ACCOMPLISHMENTS – PERIOD ENDING SEPTEMBER 30, 2021

- Passed 2,761 of 3,582 executed test runs for Functional Rollout 2 User Acceptance Testing.
- Completed Development activities for Functional Rollout 3.

#### PLANNED MAJOR ACTIVITIES & MILESTONES BY DECEMBER 31, 2021

- Complete Contractor Acceptance Testing (Part-B) for Functional Rollout 2.
- Provide details of the schedule replanning effort and adjustments to the remaining project tasks and milestones.

#### PROJECT SCHEDULE STATUS TIMELINE<sup>7</sup>

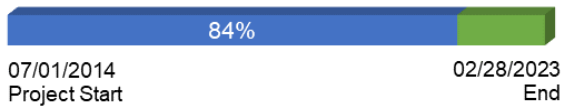

#### FISCAL YEAR 2021-22 MAJOR MILESTONES

NOTE: Milestones will be added after the schedule replanning efforts are finalized.

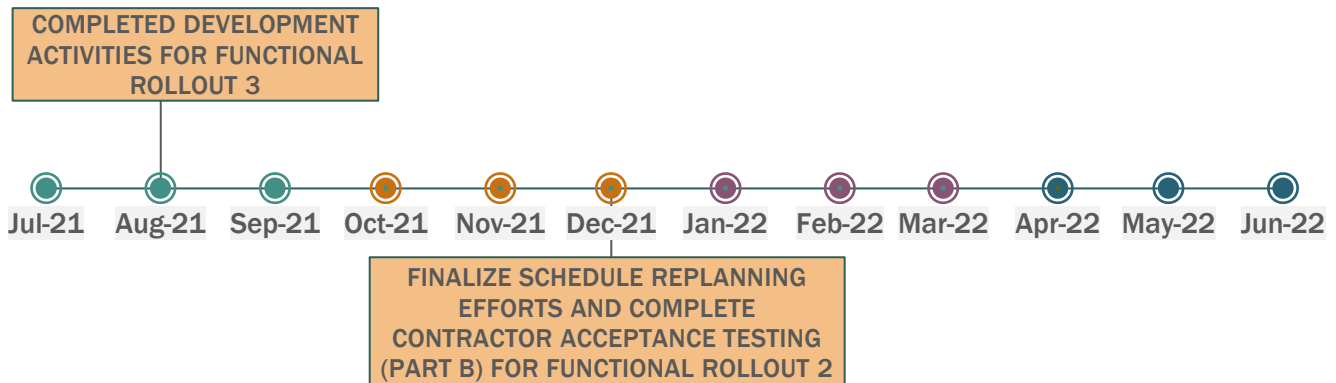

<sup>7</sup> CalSTRS does not anticipate meeting this project completion date. A revised date is being determined.



## MAJOR ENTERPRISE TECHNOLOGY PROJECTS

### TRANSFORMATION READINESS

The Transformation Readiness project supports business areas and prepares staff for impacts, changes, and benefits from large enterprise modernization efforts.

#### PROJECT BUDGET

\$18.3 Million

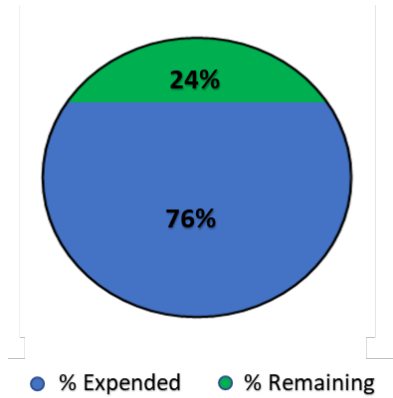

#### ACCOMPLISHMENTS – PERIOD ENDING SEPTEMBER 30, 2021

- Reviewed draft training materials for Functional Rollout 2 training courses for staff, members, and employers in collaboration with business area training staff and subject matter experts.
- Kickoff Technology Services Process Readiness documentation effort with Subject Matter Experts.
- Finalized initial draft of change leader toolkit, starting review, feedback, and refinement.
- Drafted Pension Solution overview materials shared at new employee onboarding.
- Developed and launched a communications matrix to better track and plan for all upcoming project communications.
- Documented Functional Rollout 3 initial analysis of the training content (9/29/21).

#### PLANNED MAJOR ACTIVITIES & MILESTONES BY DECEMBER 31, 2021

- Conduct a Pension Solution Town Hall and Open House to increase organizational awareness of project activities.
- Draft the Train-the-Trainer and Staff Training Schedules based on updated Pension Solution Project schedule.
- Deliver Change Leadership Toolkit to change champions and change leaders.
- Finalize Pension Solution overview materials shared at new employee onboarding.
- Draft Change Management Activity Schedule in support of Pension Solution Project, when known.

#### PROJECT SCHEDULE STATUS TIMELINE

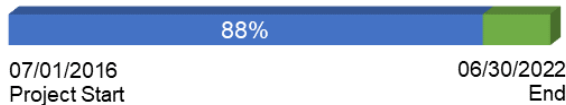







#### FISCAL YEAR 2021-22 MAJOR MILESTONES

Because the schedule for this project is dependent on the Pension Solution Project schedule, the expected milestone dates are unknown until the schedule for the Pension Solution Project has been reforecast.



## OTHER ENTERPRISE PROJECTS UNDER \$1 MILLION

The following table summarizes other reportable enterprise projects under \$1 million during the first quarter.

Project and Description	Project Duration	Schedule (Status)	Project Budget <sup>8</sup>	Budget Expended <sup>9</sup>	Budget (Status)
<b>CalSTRS.com Modernization</b> Provides CalSTRS with a modern public-facing website that meets the latest web architecture standards and caters to members, investors, and all other CalSTRS business partners' needs.	Sep 2020 – Feb 2022		\$678,123	\$0	
<b>Print to Mail Software</b> Install and integrate Pitney Bowes print-to-mail software, Planet Press, between the new pension administration system and our centralized printer. Provides the ability to process outgoing member correspondence in zip code order and varying page-counts, to align with how it is generated by BenefitConnect. Provides a modern print-to-mail software solution with more automated workflow and built-in security oversight protections and risk-mitigation measures.	Dec 2020 – Oct 2021	 <sup>10</sup>	\$559,283	\$0	
<b>SAP Concur (Travel and Expense Management)</b> Adds a new digital service to the CalSTRS portfolio while significantly improving the end user experience. Provides travelers a "one stop shop" for all travel and expense needs which does not exist in the current application and significantly decreases the time it takes users to create and submit expense reports, while reducing the high number of errors during the expense submission process.	Jan 2020 – July 2021		\$865,000	\$591,008	

Schedule & Budget Indicators  On Track  Warning  Critical  Complete  Cancelled  Not Started

<sup>8</sup> Project Budget – Amount represents the sum of the projects' prior years' actual expended, remaining encumbrances, and current and future years budgeted amounts.

<sup>9</sup> Budget Expended – Amount represents the total expended.

<sup>10</sup> Print to Mail Software Schedule – The schedule is dependent on the implementation schedule for the Pension Solution Project.